

Small & medium capacity air pump

XP-40 / 60 / 80



Pressure type

Dust control "Dust trap filter"

Easy restart by micro switch (XP-60 / 80 only)

No need of grounding

Outdoor (Rainproof) use

Applications

- Septic tank (biological contact aeration)
- Air injection for bubble bath
- Small capacity compressor

Dimensions

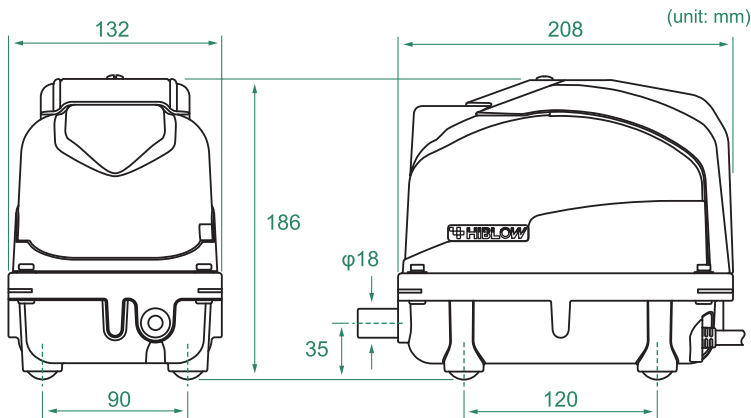

Specifications

		XP-40	XP-60	XP-80
Rated voltage	V	AC100 / 120 / 230		
Power frequency	Hz	50	60	50 / 60
Rated pressure	kPa	12.8	14.7	
Airflow volume	L/min	40	60	80
Power consumption	W	30	39	58
Sound level	dBA	33	35	36
Weight	kg	4.1	4.3	

Performance Curve

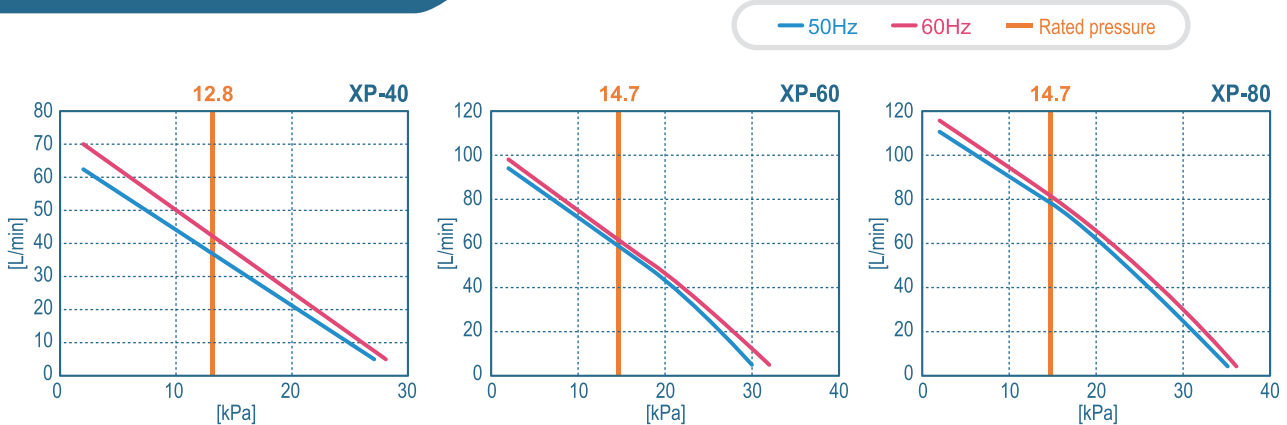

* All characteristics values are only for reference, and are not guaranteed values.

* Note that the operating temperature for our pumps is 41°F(5°C) to 104°F(40°C).